

Rotary turnstile for access of persons to areas including representative buildings. Robust, durable construction with motor control and glass wings, including delimiting railing.



Description

- Elegant stainless steel construction with wings made from glass or plexiglass.
- Control unit, which is made from BLDC motor with planetary gearbox and brake, which ensures immediate stopping of the turnstile.
- Automatic release in case of power failure.
- High level of operational safety.
- After the opening impulse, the rotor is set in motion by light pressure to the wing.
- Include delimiting railing
- Capacity 25 pers. / min.

Technical specification

MODEL:	SGR 120
Dimensions:	1430 x 1340 x 1060 mm
Cabinet material:	nerez. konstrukce, křídla sklo
Suitable for:	indoor
Width of passage:	760 mm
Capacity of passage:	40 pers./min.
Power supply:	230 V AC, 50Hz
Motor:	24 VDC/25 W
Weight:	90 kg
Operating load:	100%
Operating temperature:	0°C až +45°C

Dimensions (mm)

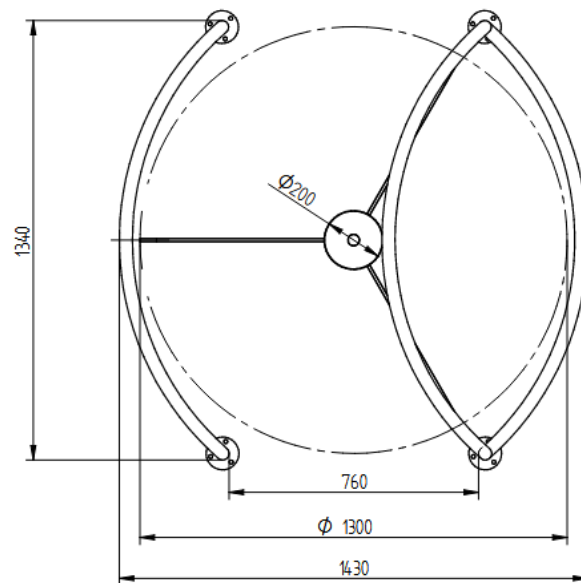
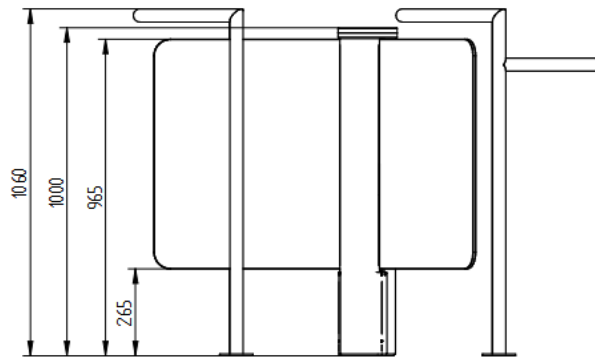

CE

*With a constant view of adopting the latest technological development
Detomatic reserves the right to amend the information above, at any time.*