

SG-213 motorized gate is designed for controlling entry to different places or as a suitable addition to turnstiles for disabled persons.



## Description

- Elegant cabinet made of stainless steel with swing barrier.
- Robust cabinet of blocked mechanism ensures reliable locked in the end positions.
- Possibility to connection to EPS.
- Information LED lights red/green.
- BLDC motor, gearbox and brake provides smooth and fast movement
- Adjustable direction of passage., automatic closing.
- Smooth and fast movement, securely locked in the end positions.
- Automatic closing after a set time if there is not passage.
- Control unit allow easy integration with any acces or ticketing systems.
- Adjustable opening/closing speed.
- Possibility of adding the railing.
- Easy instalation on a flat and solid floor.

## Technical specification

<b>MODEL:</b>	<b>SG 213</b>
Power supply:	230 V AC, 24 V DC
Closing:	automatic
Dimensions:	180 x 780 x 1000 mm
Material:	stainless steel
Instalation:	indoor/ outdoor
Width of passage:	max. 900 mm
Capacity of passage:	30 pers./min.
Min. open./closing time:	4 sec.
Motor:	24 VDC/25 W
Weight:	50 kg
Pass mode:	both side
Operating temperature:	-10°C - + 45°C

## Dimensions (mm)

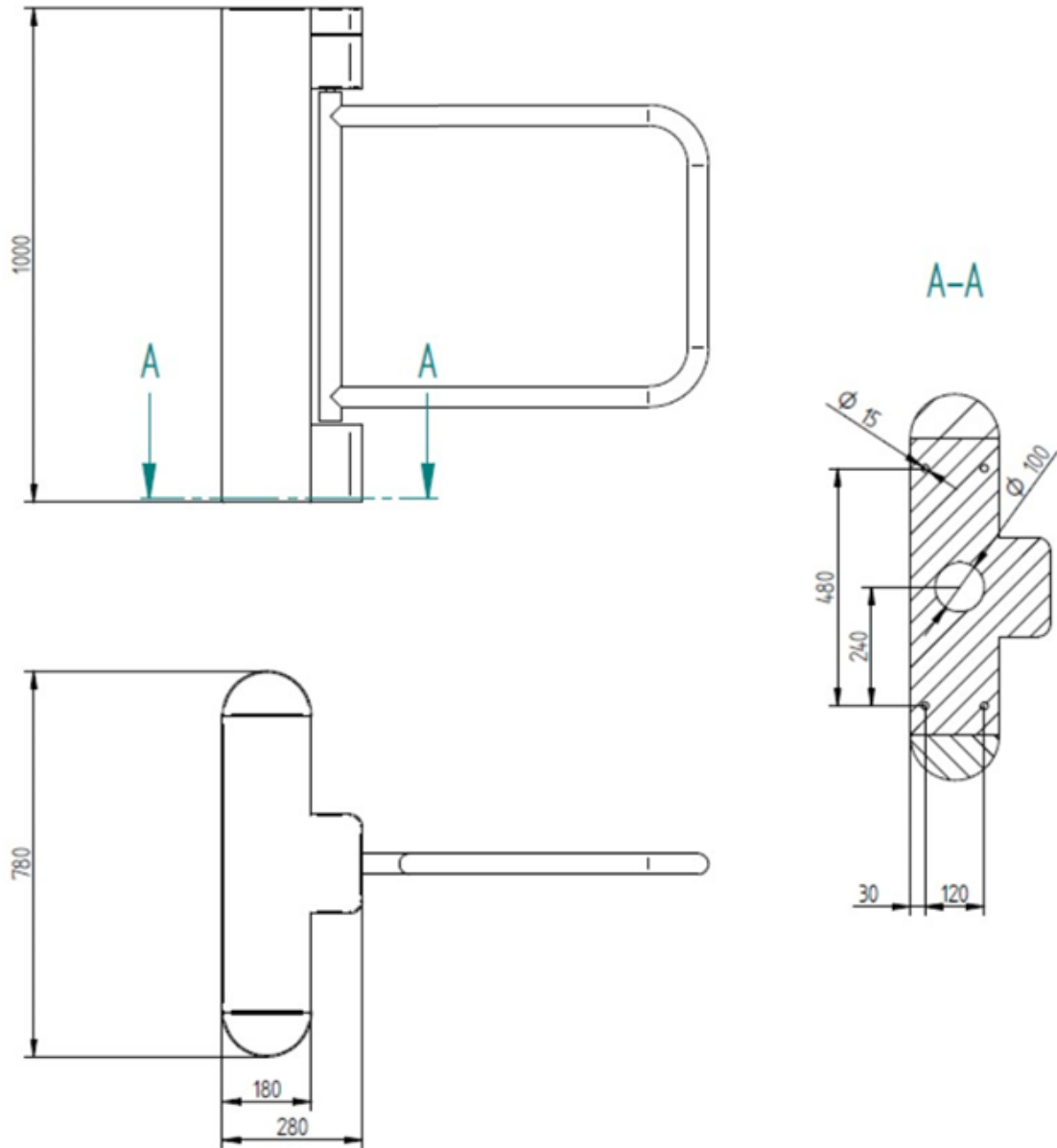

CE

*With a constant view of adopting the latest technological development  
Detomatic reserves the right to amend the information above, at any time.*