

Two-way motorized turnstile in robust, durable and elegant design.



Description:

- The cabinet is made of brushed stainless steel, 1.5 mm thick, rotating arms made of stainless steel tubes, diameter 40 mm, length 500 mm.
- Removable cover with lock.
- Brushless motor with gearbox and brake, automatic arm folding in case of alarm (anti-panic)
- Built-in control unit.
- Controlled entrance, automatic exit.
- Double-sided LED guidance pictograms.
- The construction of turnstile allows the integration of a payment machine for collecting fees, including a discount voucher printer.

Technical specification:

MODEL:	TRISTAR 101
Dimensions:	1050 x 1000 x 780 mm
Cabinet material:	stainless steel
Installation:	indoor or outdoor
Režim průchodu:	1 way, 2. way, both ways
Capacity:	40 pers./min.
Passage:	600 mm
Power supply:	30 W
Closing:	the movement must be completed
Weight:	45 kg
Power supply:	230 V AC, 50Hz, 40 W
Indicators:	pictograms both side

Dimensions: (mm)

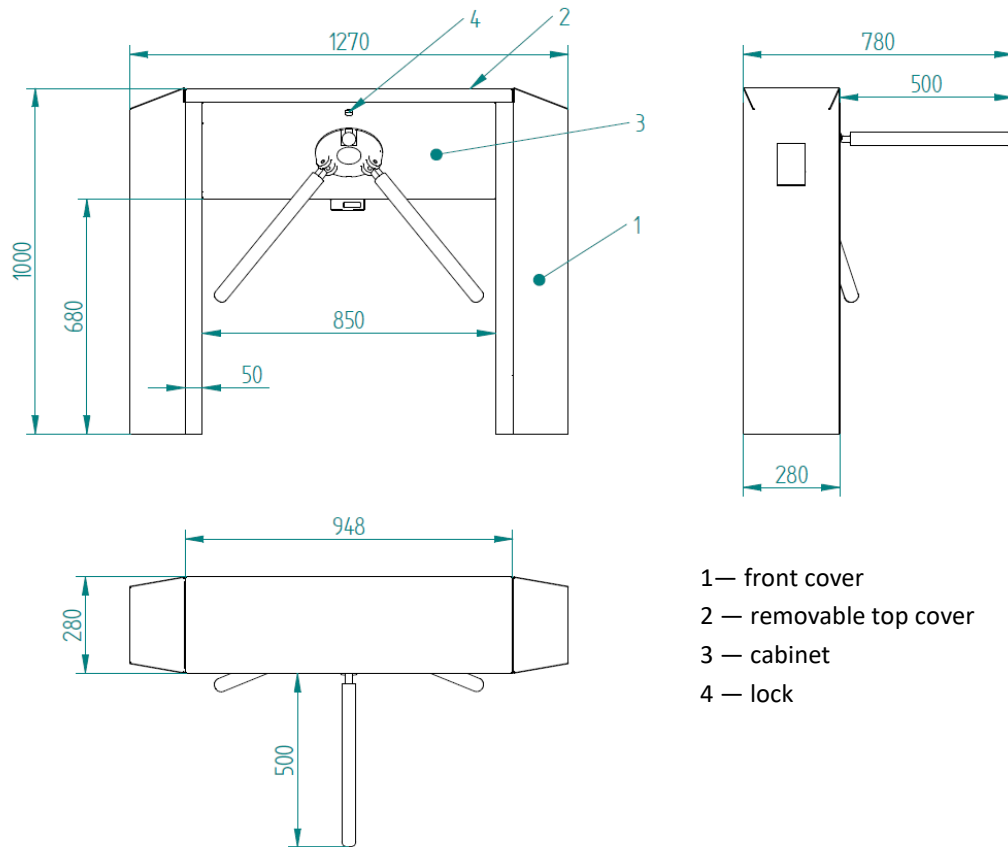

TRISTAR 101-DL

This model is equipped with a double rotor blocking system for applications with increased risk of forced override (suitable for ticket systems with higher traffic intensity).



*With a constant view of adopting the latest technological development
Detomatic reserves the right to amend the information above, at any time.*