

Two-way motorized turnstile in robust, durable and elegant design.

## TRISTAR 105



### Description:

- The cabinet is made of brushed stainless steel, 1.5 mm thick, rotating arms made of stainless steel tubes, diameter 40 mm, length 500 mm.
- Removable cover with lock.
- Brushless motor with gearbox and brake, automatic arm folding in case of alarm (anti-panic)
- Built-in control unit.
- Controlled entrance, automatic exit.
- Double-sided LED guidance pictograms.
- The construction of turnstile allows the integration of a payment machine for collecting fees, including a discount voucher printer.
- The TRISTAR 105-DL is equipped with a double rotor locking system

### Technical specification:

<b>MODEL:</b>	<b>TRISTAR 105</b>
Dimensions:	1060 x 1060 x 260 mm
Cabinet material:	brushed stainless steel
Installation:	outdoor and indoor
Width of passage:	550 mm
Capacity of passage:	40 osob/min.
Power supply:	230 V AC, 50Hz
Motor:	24 V DC/30 W
Weight:	50 kg
Working temperature:	- 20°C až +70°C

# Dimensions(mm)

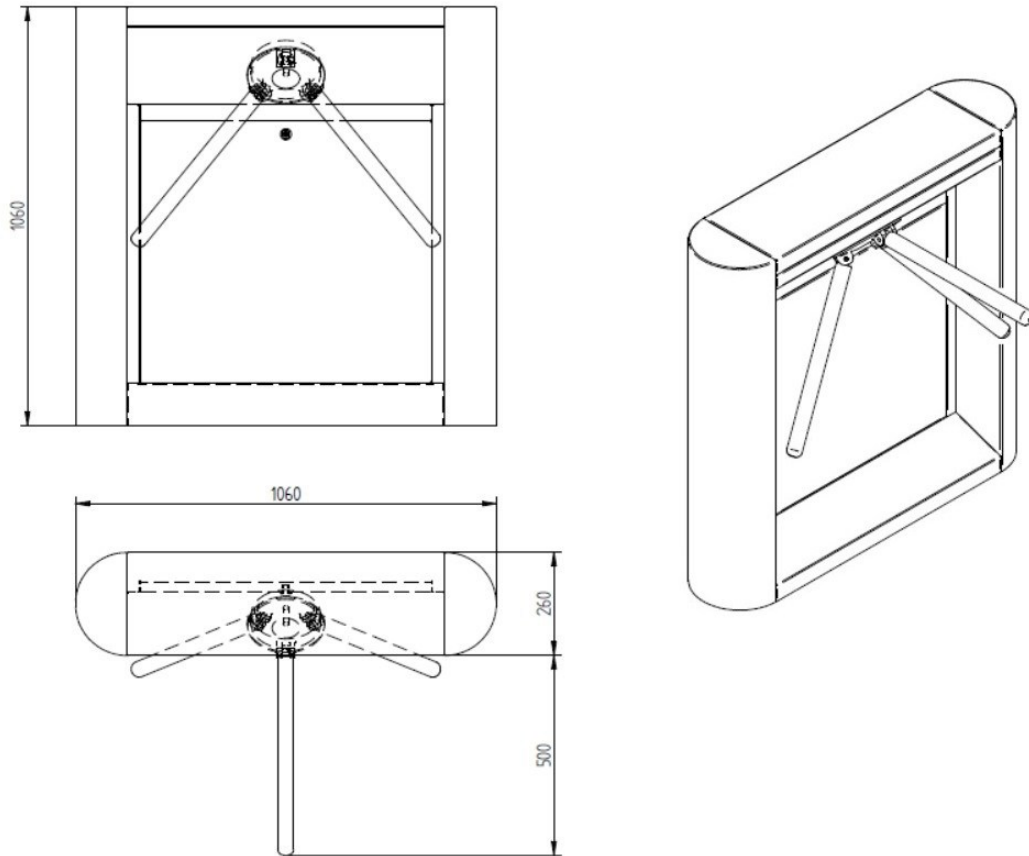

CE

*With a constant view of adopting the latest technological development  
Detomatic reserves the right to amend the information above, at any time.*